



## Compact heat meter SVM F2-444

A powerful energy meter with a mechanical flow sensor

[Data sheet](#)

## Description

SVM F2-444 is a compact energy meter consisting of an F2 integrator, a mechanical flow sensor and paired temperature sensors. The heat meter temperature range is 32...+248° F. The flow sensor is a single jet wing wheel flow sensor with  $\pm 2\%$  inaccuracy, and is available in the flow sizes qp 2.64, 6.6 and 11 gal/m. The flow sensor is completely dry-running with a magnetic coupling. Special carbide bearings ensures long term stability.

The temperature sensors are matched and can be mounted directly or in pockets. The length for direct mounted temperature sensors is 1.02 in., and for pocket mounted 1.77 in.

All parts are factory-assembled.

## Advantages

- Approved according to EN1434
- Battery or net supplied
- M-Bus communication
- Two extra pulse inputs or outputs
- 2 account days, 37 monthly registers
- Short integration time, 5 seconds
- Long term stability

## Installation

SVM F2-444 can be installed horizontally, vertically or inclined. The best meteorological results are achieved by horizontal installation. The meter shall be installed in a straight pipe, always to be completely filled with water. Avoid installation in positions where air can be trapped, such as high points. A straight inlet pipe of minimum  $5 \times DN$  is recommended. The return temperature sensor is pre-installed in the flow sensor. The forward temperature sensor should be installed in a T-piece or a valve. The meter can be installed in the forward pipe, with modified integrator settings.

## Communication

SVM F2-444 is equipped with M-Bus as standard. The meter has two extra pulse inputs. These may be used for hot and cold water meters. As an alternative, two extra pulse outputs for energy and volume may be chosen, instead of the pulse inputs.

## Display

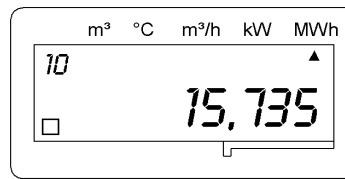

Example of a the display

SVM F2-444 is equipped with an LCD. The values are displayed with 7 digits, and the decimals are clearly indicated. The current display sequence is indicated with two digits in the upper left corner of the display. The unit of the displayed value is indicated with an arrow. Volume pulses are indicated with a flashing square in the lower left corner of the display. If an error occurs, this square is shown constantly. See also the table below, "F2-444 Display Sequence".

Sequence	Description	Format
1 0	Accumulated energy - Default position	
1 1	Accumulated volume according to the flow sensor	
8 8	Display test	
1 3	Accumulated volume - pulse register 1*	
1 4	Accumulated volume - pulse register 2*	
1 5	Error code	
1 6	Error time - accumulated time for current error	Minutes
2 0	Momentary power	
2 1	Momentary flow	
2 2	High temperature	
2 3	Low temperature	
2 4	Temperature difference	
3 0	Account days - date when values were stored	YYMMDD
3 1	Accumulated energy	
3 2	Accumulated volume according to the flow sensor	
3 3	Accumulated volume according to accumulated energy	
3 4	Accumulated volume - pulse register 1*	
3 5	Accumulated volume - pulse register 2*	
3 6	Error code on account day	
3 7	Error time on account day	Minutes
4 0	Monthly registers - date when values were stored	YYMMDD
4 1	Accumulated energy	
4 2	Accumulated volume according to the flow sensor	
4 3	Accumulated volume according to accumulated energy	
4 4	Accumulated volume - pulse register 1*	
4 5	Accumulated volume - pulse register 2*	
4 6	Error code on date for data storage	
4 7	Error time	Minutes
5 0	Operation time	Hours
5 1	Current date	YYMMDD
5 2	Current time	HHMM
5 3	Recommended date for battery exchange	YYMMDD
6 0	Communication address	
A X	Meter number	
B X	Serial number	
6 3	Pulse value	L / Imp
6 4	Flow sensor placing, high or low temperature (forward or return)	H or L
7 0	Accumulated volume according to accumulated energy	
7 1	Last read accumulated energy via communication**	
7 2	Time since last reading via communication**	Hours
7 3	Accumulated error time	Minutes
7 4	Previous error code	
7 5	Accumulated time for previous error code	Minutes

## Technical data

### Calculator

<b>Power supply</b>	
Battery supplied	3V / 2,2Ah, 10 years life time
Mains supplied, with back-up battery	230V±10%, 45...65Hz
<b>Temperatures</b>	
Temperature range	0...+190°F
Temperature difference	2... 120° K
Temperature resolution	0.02°F
Operating temperature	+41° F till +131° F
Storage/transport temperature	-4° F till +158°F
<b>Display</b>	
LCD 7+2 digits	
<b>Communication</b>	
M-Bus acc. to EN1434-3	Standard
2 extra pulse inputs	Pulse counters 264:1 (gal/impulse)
Frequency	Max 12 Hz
Pulse width	Min 40ms
Voltage	3V
Current	3µA
Pulse outputs	Open collector type
Output 1	Energy, 0,1 kW h/imp
Output 2	Volume, .26gal/impulse
Pulse width	250 ms
Max voltage	30 V
Max current	20 mA
Protection class	IP54
Environmental class	C acc. to EN1434
Approvals	PTB 22.15/98.01, SP 15 42 03

## Temperature sensors

### TDA26 for direct mounting

Type	Pt100/Pt500
Measuring range	32...+284° F
Temperature difference	2... 100 K
Tolerance	Class B
Thermal response time	1,8 s
Pressure rating	PN16
Dimensions	
Diameter	.14 in
Length	1.02 in
Cable	2-wire
Length	6.56 ft
Resistance	0,2955 ohm

### TL045 for pocket mounting

Type	Pt100/Pt500
Measuring range	32...+284° F
Temperature difference	2... 100 K
Tolerance	Class B
Thermal response time	1,8 s
Pressure rating	PN16
Dimensions	
Diameter	.20 in
Length	1.8 in
Cable	2-wire
Length	6.56 ft
Resistance	0,2955 ohm

## Flow sensor

<b>Nominal size</b>			
DN (in.):	✓ 60	✓ 60	✓ 79
Thread connections	G¾B	G¾B	G1B
<b>Flow</b>			
Qp (gal/m)	✓ 2.6	✓ 6.6	✓ 11
Qs (gal/m)	✓ 5.3	✓ 13	✓ 22
Qi horizontally (gal/m):	✓ .05	✓ .13	✓ .22
Qi vertically (gal/m):	✓ .11	✓ .26	✓ .44
Qi horizontally (gal/m):	✓ .21	✓ .53	✓ .88
Qi vertically (gal/m):	✓ .26	✓ .66	✓ 1.1
Flow at 0,1 bar pressure			
loss (gal/m):	1.8	4.8	7.5
Length L (in.):	4.3	4.3	5.1
Temperature range:		+32...+248° F	
Mounting position:		Horizontally, vertically or inclined	
Cable length:		9.84 ft	
Approval:		PTB 22.16/82.01	

## Dimensions

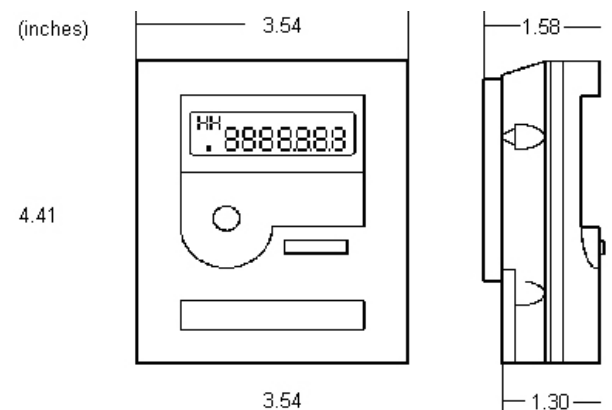
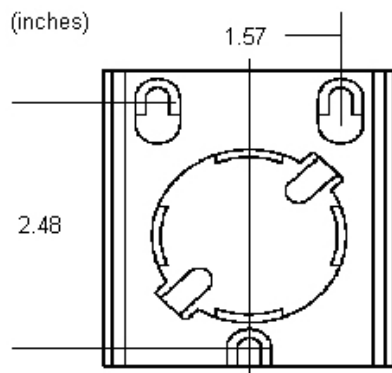
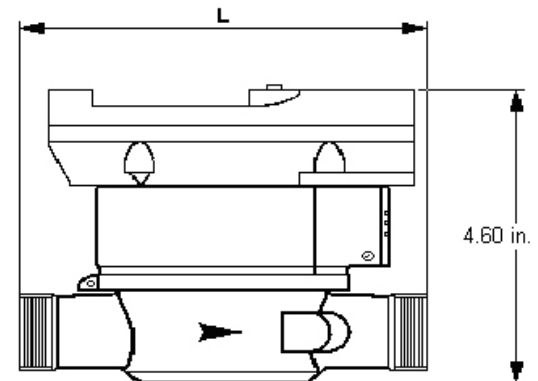

## Ordering F2-444

F2-444 is available in a number of standard versions. All are battery supplied and equipped with TDA26 temperature sensors for direct mounting, with a straight cable. The energy unit is MWh. The flow sensor may be chosen for mounting in the forward pipe (high temperature) or return pipe (low temperature), and is available in the sizes 2.64 and 6.6 gal/m. The calculator can be programmed for two pulse outputs (energy 0.1 kWh/pulse, and volume 1 lpulse) or two pulse inputs (pulse counters 1:1).

For all other settings and alternatives the "Special ordering form" is to be used.

## F2-444 standard versions

Size	Mounting, H/L	Pulse in/out	Article no.
DN15, Qp 0,6	Low temperature	out	K11112LB11100
DN15, Qp 0,6	High temperature	out	K11112HB11100
DN15, Qp 0,6	Low temperature	in, 1:1	K11112LB12100
DN15, Qp 0,6	High temperature	in, 1:1	K11112HB12100
DN15, Qp 1,5	Low temperature	out	K13112LB11100
DN15, Qp 1,5	High temperature	out	K13112HB11100
DN15, Qp 1,5	Low temperature	in, 1:1	K13112LB12100
DN15, Qp 1,5	High temperature	in, 1:1	K13112HB12100

## Special ordering form F2-444

Mark each choice with an "X".

Standard options are marked in bold letters.

Calculator	Option	Choice
Temp. Sensors	<b>Pt 100</b>	<input type="checkbox"/>
	Pt 500	<input type="checkbox"/>
Installation	<b>Return, low T</b>	<input type="checkbox"/>
	Forward, high T	<input type="checkbox"/>
Power supply	<b>Battery</b>	<input type="checkbox"/>
	Mains	<input type="checkbox"/>
	Other (bus, 24 V):	<input type="checkbox"/>
Pulse value <sup>1)</sup>	<b>.26 gal/p</b>	<input type="checkbox"/>
	<b>.66 gal/p</b>	<input type="checkbox"/>
	Other:	<input type="checkbox"/>
Energy unit	<b>MWh</b>	<input type="checkbox"/>
	Other (kWh, GJ, MBTU):	<input type="checkbox"/>
Extra inputs	<b>None (outputs)</b>	<input type="checkbox"/>
	Inputs, <b>.66 gal/p</b>	<input type="checkbox"/>
	Inputs, other pulse value:	<input type="checkbox"/>
Country code	<b>Standard (SE)</b>	<input type="checkbox"/>
	Other (DE, GB, CH, AT):	<input type="checkbox"/>
Communication	<b>M-bus (standard)</b>	<input type="checkbox"/>
	SIOX	<input type="checkbox"/>
<b>Flow sensor</b>		
Flow, size	2.64 gal/m, DN 15, 4.33 in.	<input type="checkbox"/>
	6.60 gal/m, DN 15, 4.33 in.	<input type="checkbox"/>
	11 gal/m, DN 20, 5.12 in.	<input type="checkbox"/>
Pulse value <sup>1)</sup>	<b>.66 gal/p</b>	<input type="checkbox"/>
	Other	<input type="checkbox"/>
<b>Temperature sensors</b>		
Type	TL045 with pockets	<input type="checkbox"/>
	TDA26 for direct mounting	<input type="checkbox"/>

1) The calculator F2 and the flow sensor must have the same pulse value.



Metrima AB

Norra Stationsgatan 93  
SE-113 64 Stockholm  
Phone: +46 8 23 60 30 Fax: +46 8 23 60 31

[www.metrima.se](http://www.metrima.se)  
info@metrима.se

2-05-01E  
060308/EW