



SVM F2

A small competent calculator for compact – wall mounting

[Data Sheet](#)

Application field

F2 is designed for metering and monitoring of heating and cooling.

Measurement

F2 measures the difference between flow temperature and return temperature, for each pulse, provided the time between pulses is longer than or equal to 5 seconds. When the time between the pulses is less than 5 seconds, the measurements of the temperature difference are made every 5th second. The energy content in the volume measured by the flow meter is calculated from the measured temperature difference. If the time between the flow meter pulses exceeds 60 seconds, a measurement will be made every 60th second. The measurement only updates temperatures that can be read off at the calculator.

Display

F2 is equipped with a LCD (Liquid Crystal Display). As optional feature the LCD can be equipped with background light.

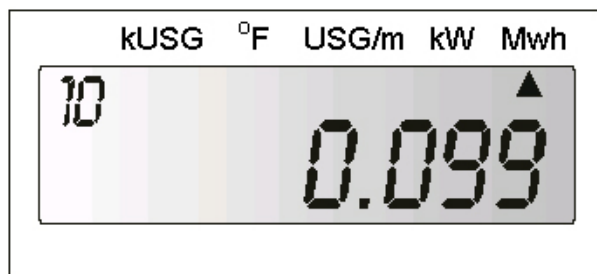

Example of a display image, showing accumulated energy.

Pulse outputs/pulse inputs

F2 has as a can be equipped outputs for energy and volume of the type "open collector". Or F2 can be equipped with two pulse inputs. The inputs can be used to read-off other meters with pulse outputs, e.g. cold and hot water meters. The meters can be read off via M-Bus.

Communication

F2 is, as standard, equipped with a M-Bus data output in accordance with EN1434-3. Read-off is possible either via an OPTO-interface or a bus connection. F2 can, as an option, be equipped with a SIOX-card for communication on a SIOX-bus. The SIOX-protocol is compatible with 820, that is all superior systems that, today, communicate with 820, can also communicate with F2.

Data

In addition to accumulated energy, the following (among others) values are accessible in F2:

- Accumulated volume for the extra pulse inputs
- Error code and accumulated time for the relevant error
- Momentary power
- Momentary flow
- Flow temperature
- Return temperature
- Temperature difference
- Total operating time
- Meter number
- Manufacturing number
- Real time clock with date function
- Pulse value
- Flow sensor placing (high or low temp.)
- Accumulated volume according to flow sensor
- Accumulated volume registered in conjunction with energy calculation
- Total error time
- Preceding error code and accumulated time for this error
- Up to 37 monthly registers (same values as for account days, see below)
- Recommended date for battery replacement.
- Two account days. On each account day the following values are stored:
 - Date
 - Accumulated energy
 - Accumulated volume according to the flow sensor
 - Accumulated volume registered during energy calculation
 - Accumulated volume for the extra pulse inputs
 - Possible error code at the time of saving and accumulated time for the relevant error

Service

F2 has a built-in service function that facilitates alteration of certain parameters in the field without a special service tool.

The following parameters can be altered:

- Time and date
- Pulse value
- Account days

- Communication address
- Flow sensor placing, high or low temperature
- Recommended date for battery replacement.

Furthermore, the total error time can be reset.

All parameters in F2 can be altered through a PC-program

Technical data

Flow sensors (with pulse output) Max. frequency 12 Hz Min. pulse length 40 ms Max. voltage 3 V Max. cable length 49.2 ft Pulse value 0.0001 - 9999 l/p	Temperature sensors Approved and matching pairs type Pt100 or Pt500 are to be used. Max. cable length 8.2 ft at 31 gauge cable area 16.4 ft at 24 gauge cable area 24.6 ft at 21 gauge cable area 49.2 ft at 1.50 mm ² cable area Max. sensor current 4 µA (RMS) for Pt 100
Power supply Battery 3V - 2.2 Ah Operation time max. 10 years Mains 230 V ± 10%, 45-65 Hz, battery 0.2 Ah as a spare	Display 7 + 2 digit LCD (back light as an option) Temperature Range 32 - 374° F Difference 2 - 120 K
Data output M-Buss (EN1434-3) Via OPTO-interface (EN60870-5) and via bus connection (terminal)	Pulse outputs Open collector Pulse length 250 ms Max voltage 30 V Max current 20 mA
Ambient temperature Operation +41° F to +131° F Storage/transport -4° F till +158° F	Pulse inputs Max. frequency 12 Hz Min. pulse length 40 ms Max. voltage 3 V
Protection class IP54 Environmental class C according to EN1434.	Alarm output Open collector Pulse length 250 ms

Dimensions
(inches)

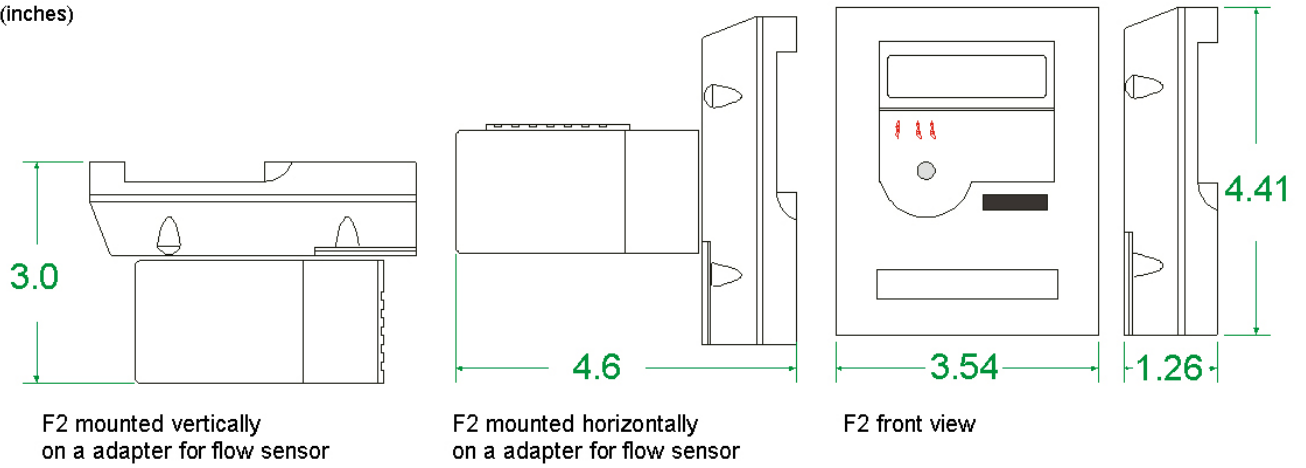

Metrifa AB

Norra Stationsgatan 93
113 64 Stockholm
Tel: +46 8 23 60 30 Fax: +46 8 23 60 31

www.metrifa.se
info@metrifa.se

3-06-02E
rev. 050309/MaSj

F2 Article number key

By combining the correct letters in the table below the correct article number is acquired for F2.

F2 ABCDEFGHIJ KLM

A	1	Pt100 2-wire measurement, flow in low temperature
A	2	Pt100 2-wire measurement, flow in high temperature
A	5	Pt500 2-wire measurement, flow in low temperature
A	6	Pt500 2-wire measurement, flow in high temperature
B	1	Battery supply
B	2	Bus supply
B	3	Mains supply 230VAC
B	5	24 VAC
C	1	Kt Input 2.5 l/p
C	2	Kt Input 25 l/p
C	3	Kt Input 250 l/p
C	4	Kt Input 2500 l/p
C	5	Kt Input 1 l/p
C	6	Kt Input 10 l/p
C	7	Kt Input 100 l/p
C	8	Kt Input 1000 l/p
D	0	KWh
D	1	MWh
D	2	GJ
D	3	MBTU
E	-	Standard order
E	S	Special, Extra information at the order, e.g. customer information
F	1	Pulse Inputs, 2.5 l/p, dec. 2
F	2	Pulse Inputs, 25 l/p, dec. 1
F	3	Pulse Inputs, 250 l/p, dec. 0
F	5	Pulse Inputs, 1 l/p, dec. 3
F	6	Pulse Inputs, 10 l/p, dec. 2
F	7	Pulse Inputs, 100 l/p, dec. 1
F	8	Pulse Inputs, 1000 l/p, dec. 0
F	9	Pulse Outputs
G	0	Backlight on display (not recommended on battery supplied meters)
G	1	No Backlight
H	0	For wall mounting, with adapter incl.
H	1	Compact mounted with Hydrometer BR431
H	2	Compact mounted with other flow sensor, with adapter incl.
H	3	With adapter for BR471
H	4	With out adapter
I	-	Standard
J	1	Standard
K	1	Country code, 3 = Standard English
L	0	Standard
M	0	Standard

Article number key

To acquire the article number just fill in the blanks

F2	A	B	C	D	E	F	G	H	I	J	K	L	M
									-	1		0	0